

**Installation, Operating and
Maintenance Instructions with
Parts Lists**

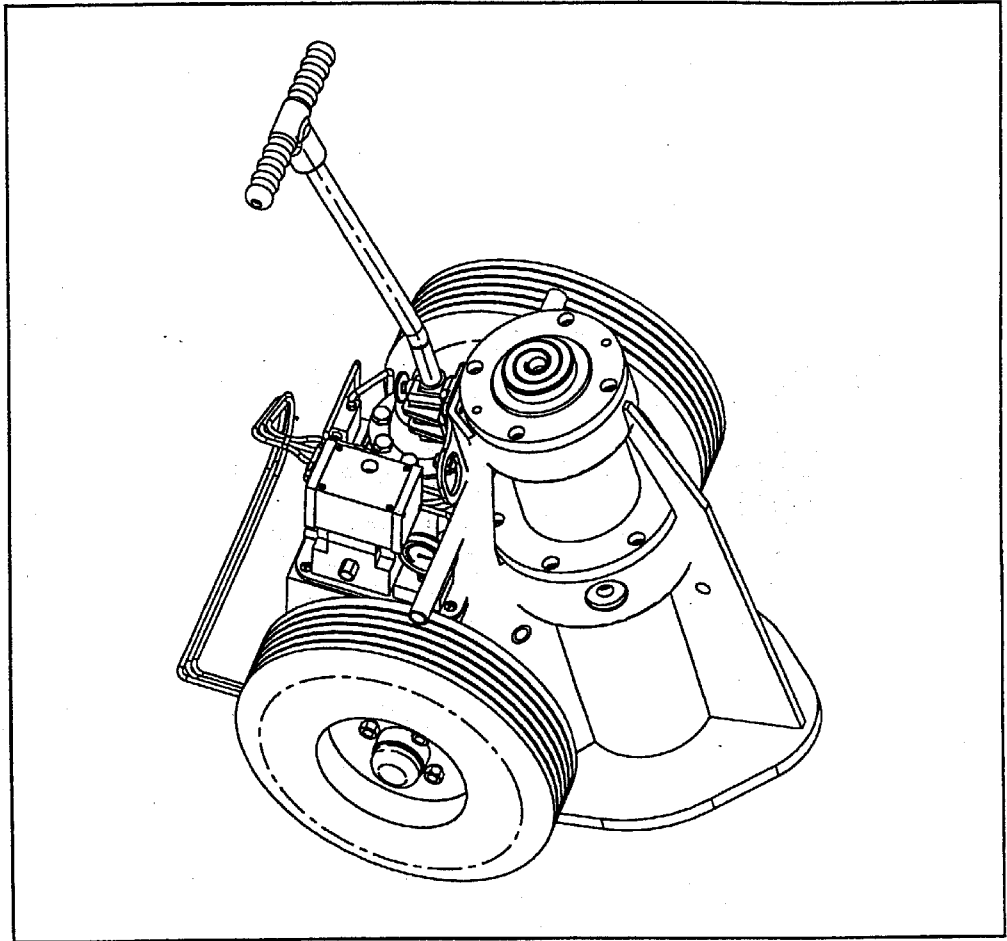

Publication Part No. BJ50

BOSSMAN Hydraulic Jack

Contents

Section I	Warnings and Important Notes	4
1-1.	National Standard ASME B30.1	4
1-2.	Hydraulic: The Bossman Jack is a (Double-Acting) Hydraulic Return Ram	4
1-3.	Duff-Norton Warranty Policy	4
Section II	Safety Precautions	4
2-1.	Hydraulic Hoses	4
2-2.	Pump	5
2-3.	Jack	5
2-4.	Air Motor	5
Section III	Operating Instructions	5
3-1.	Operation	5
3-2.	Procedures and Precautions	5
3-3.	Install the Air Fittings	6
Figure 3-1.	Recommended Air Line Connection	6
Section IV	Inspection	6
4-1.	Inspection Classification	6
4-2.	Initial Inspection	6
4-3.	Frequent Inspection	6
4-4.	Periodic Inspection	7
4-5.	Load Test	7
Table 4-1.	Specifications	7
Section V	Preventative Maintenance	8
5-1.	Lubrication of the Air Driven Motor	8
5-2.	Bleeding Air from the System	8
5-3.	Draining and Flushing the Reservoir	8
5-4.	Hydraulic fluid level	8
5-5.	Adding oil to the reservoir	8
5-6.	Maintenance cleaning	8
Section VI	Accessory Installation	9
6-1.	Hydraulic Gauge	9

IMPORTANT — CAUTION

This manual contains important information for the correct installation, operation and maintenance of the equipment described herein. All persons involved in such installation, operation and maintenance should be thoroughly familiar with the contents. To safeguard against the possibility of personal injury or property damage, follow the recommendations and instructions of this manual and keep it for further reference.

WARNING

The equipment shown in this manual is intended for industrial use only and should not be used to lift, support, or otherwise transport people.

Figure 6-1.	Hydraulic Gauge	9
Section VII	Troubleshooting Guide	9
Figure 7-1.	Hydraulic Schematic.....	9
Section VIII	Parts Drawings and Lists	13
8-1.	Hydraulic Pump	13
Figure 8-1.	Hydraulic Schematic, for Pump.....	13
Figure 8-2.	General Pump Assembly, Side View	14
8-2.	Parts List General Pump Assembly, Side View	14
Figure 8-3.	General Pump Assembly - Top View	15
8-3.	Parts List for General Pump Assembly - Top View	15
Figure 8-4.	General Pump Assembly - Bottom View	16
8-4.	Parts List for General Pump Assembly - Bottom View	16
Figure 8-5.	External Relief Valve	17
8-5.	Parts List for External Relief Valve	17
Figure 8-6.	General Pump Assembly - Section A-A	18
8-6.	Parts List for General Pump Assembly - Section A-A	18
Figure 8-7.	Basic Pump Assembly - Section B-B	19
8-7.	Parts List for Basic Pump Assembly - Section B-B	19
Figure 8-8.	Air Motor for Pump	20
8-8.	Parts List for Air Motor for Pump	20
Figure 8-9.	Hand Switch Assembly	21
8-9.	Parts List for Hand Switch Assembly	21
Figure 8-10.	Valve Assembly	22
8-10.	Parts List Valve Assembly	23
Figure 8-11.	Load Lowering Valve	24
8-11.	Parts List for Load Lowering Valve	25
Figure 8-12.	5026 BOSSMAN Jack Assembly	26
8-12.	Parts List 5026 BOSSMAN Jack Assembly	27
8-13.	Lowering Valve Specifications	25
8-14.	Lowering Valve Operation.....	25

Section I

Warnings and Important Notes

1-1. National Standard ASME B30.1

Duff-Norton cannot be responsible for damage or injury caused by unsafe use, inadequate or misapplication of products. Safe use of hydraulic jacks is covered in the American National Standard ASME B30.1. Owners and operators should obtain this Standard and be familiar with its contents. A copy of this standard may be obtained from: The American Society of Mechanical Engineers, 34 East 47th Street, New York, NY 10017

1-2. Hydraulic: The Bossman Jack is a (Double-Acting) Hydraulic Return Ram Caution

Never Use Double-Acting Rams With Single-Acting Pumps.

Double-acting rams advance and retract under hydraulic pressure. Power pumps used with double-acting rams must provide a complete loop, so that system fluid can return to the pump reservoir. The use of single-acting pumps with double-acting rams will cause over-pressurization of the ram.

1-3. Duff-Norton Warranty Policy

Subject to the condition stated herein, Duff-Norton will repair or replace, without charge, any parts proven to Duff-Norton's satisfaction to have been defective in material or workmanship. Claims

must be made within one year after the date of shipment.

This warranty is null and void for:

1. Units or any parts that became inoperative because of improper maintenance, eccentric loading, overloading, chemical or abrasive action, excessive heat, or other abuse.
2. Equipment which has been altered or modified by anyone without Duff-Norton's authorization .
3. Equipment and accessories not of Duff-Norton's manufacture and warranted only to the extent of the manufacture's warranty and subject to the same conditions as stated above regarding improper maintenance, abuse, overloading, etc.
4. Except as stated herein, Duff-Norton makes no other warranties, expressed or implied including warranties of merchantability and fitness for a particular purpose.

If you have any questions concerning warranty repair, please contact the factory for the name and address of your nearest Duff-Norton warranty repair facility.

Authorization for return must be received from the Duff-Norton Company before returning any equipment for inspection or warranty repair.

Section II

Safety Precautions

! WARNING

To help prevent personal injury, all warning statements must be observed

2-1. Hydraulic Hoses

- Before operating the pump, all hose connections must be tightened using proper tools.
- Do not over tighten, connections need only be secure and leak-free. Over tightening may cause premature thread failure or may cause high pressure fittings to split at pressures lower than their rated capacities.
- If a hydraulic hose ever ruptures, bursts, or needs to be disconnected, immediately shut off the pump. Never attempt to grasp a leaking hose under pressure with your hands. The force of escaping hydraulic fluid could cause serious injury.
- Do not subject the hose to a potential hazard such as fire, extreme heat or cold, sharp sur-

faces, or heavy impact.

- Do not allow the hose to kink, twist, curl or bend so tightly that the oil flow within the hose is blocked or reduced.
- Periodically inspect the hose for wear because any of these conditions can damage the hose and possibly result in personal injury.
- Do not use the hose to move the attached equipment. Stress may damage the hose and possibly cause personal injury.
- Hose material and coupler seals must be compatible with the hydraulic fluid used. Hoses also must not come in contact with corrosive materials, such as creosote-impregnated objects and some paints.
- Consult the manufacture before painting a hose.

NEVER paint the couplers. Hose deterioration due to corrosive materials may result in personal injury.

2-2. Pump

- Do not exceed the PSI hydraulic pressure rating noted on the pump nameplate or tamper with the internal high pressure relief valve. Creating pressure beyond the rated capacity may result in personal injury.
- Before replenishing the oil level, retract the system to prevent overfilling the pump reservoir. An overfill may cause personal injury due to excess reservoir pressure created when the cylinders are retracted.

2-3. Jack

To safeguard against worker injury

- Do not overload jack
- Do not lift people or loads over people

- Do not operate damaged or malfunctioning jack
- Do not apply off center loads
- Do not alter original equipment
- Do not remove or obscure warning labels
- Do support jack base securely
- Insure all personnel are clear of load when lifting or lowering load
- Do read and follow instructions

2-4. Air Motor

- Disconnect the air supply when the pump is not in use or when breaking any connection in the hydraulic system.
- It is recommended that a shut-off valve or quick disconnect be installed in the air line to the pump unit. Close the shut-off valve before connecting the air line to the pump.

Section III

Operating Instructions

The operator should familiarize himself with the jack.

3-1. Operation

Note

The jack system basically consists of a pump, a ram and a high pressure hose assembly.

3-2. Procedures and Precautions

The following procedures and precautions should be observed when operating The Bossman Jack.

- A. Determine if the load is within the load rating of the jack ram. For normal service, hydraulic jack should be used under controlled conditions to raise or lower axial loads at or less than 85% of their rated capacity.
- B. Keep all capacity markings and warning labels clearly visible.
- C. Before you start a job, read the instruction manual for the hydraulic equipment you expect to use, and know how it works. Check the operation of each component, including valves and controls, prior to engaging the load.
- D. Firmly support the base of each jack in such a manner that cannot shift under load. The entire base area must be in contact with a firm, even surface. If the lifting area does not afford these conditions use flat base plates and shims to achieve them.
- E. Properly engage the load. The lifting point of each ram in the system should be fully and properly engaged with the load before raising it.
- F. Center the load on the lifting point. The lifting point of the jack must be at the balance-point of the load. Make sure the load is well-centered and equally distributed on jack system.
- G. Off-center loading is dangerous and should be avoided.
- H. Clear the lifting area and the load of all unnecessary personnel and obstructions before the load is lifted or lowered. Assign one member of the lifting crew to keep other people at safe distance.
- I. Do not lift people or support loads over them. High Pressure hydraulic equipment is designed for industrial use only.
- J. High pressure hydraulic rams and components should not be dropped or thrown. Sudden, high impact can seriously damage hydraulic equipment, making it unsafe and unreliable for future use.
- K. Use only manufacturers' recommended extenders and lifting attachments. The use of extenders must be authorized by qualified personnel, and only one extender per set-up should be employed.
- L. Do not drag high pressure hydraulic equipment

by connected hose assemblies. This will cause fatigue and abrasive damage to hose wall, which can result in costly and dangerous hose failures.

- M. Do not weld near hydraulic components. Liquid hydraulic fluid under normal atmospheric conditions is not flammable but, it becomes an easily ignited flammable vapor if forced out of tiny holes.
- N. In the event of unusual occurrence or noise, do not operate your high pressure hydraulic system.

3-3. Install the Air Fittings

Remove the thread protector from the air inlet, and install the air supply fittings (not included) as

shown in Figure 3-1. Minimum air supply must be 50 CFM and 90 PSI, with 100 PSI being the maximum. Secure your pump fitting to the air supply. The minimum air hose recommended is 3/4" ID.

IMPORTANT:

Seal all external connections with a high-quality, nonhardening thread sealant. Teflon tape can be used to seal hydraulic connections if only one layer of tape is used. Apply the tape carefully, two threads back, to prevent it from being pinched by the coupler and broken off inside the system. Any loose pieces of tape could travel through the system and obstruct the flow of oil or cause jamming of precision-fit parts.

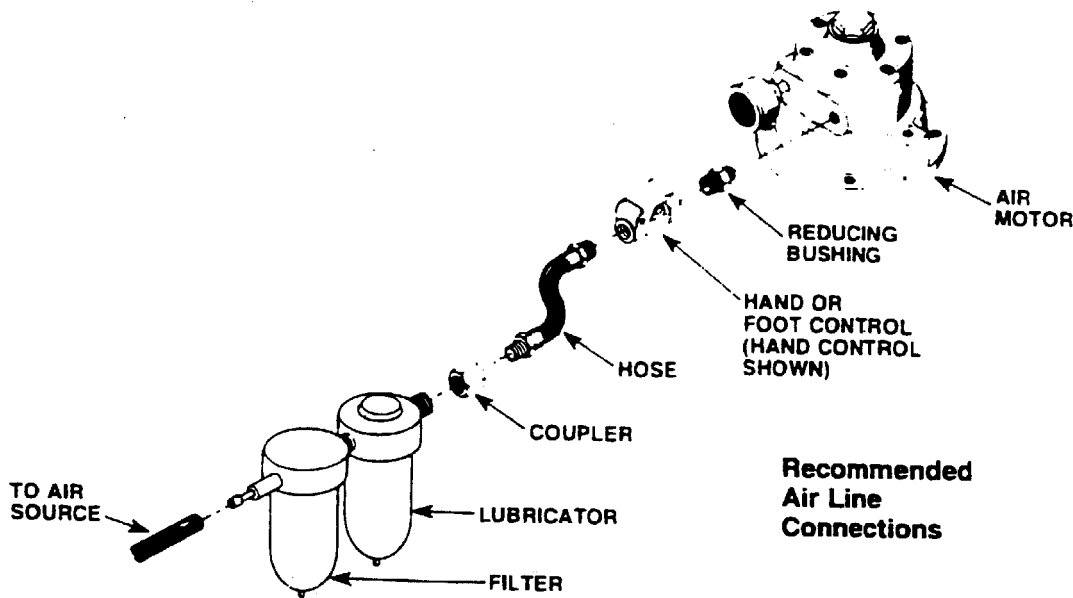

Figure 3-1. Recommended Air Line Connection

Section IV Inspection

The inspection classification herein are minimum requirements and should be augmented when experience from operating conditions dictate.

4-1. Inspection Classification

The jack inspection classification consists of initial inspection prior to use and general classifications designated as Frequent and Periodic Inspection. Inspection should be performed based on the degree of exposure to wear, deterioration or malfunction.

4-2. Initial Inspection

Any new or repaired jack should be tested for its ability to lift its rated load prior to use. See Table 4-1

for applicable load capacity.

4-3. Frequent Inspection

Visual inspection by the operator or other qualified, designated personnel.

- A. Normal service — one month
- B. Severe service — before each use or daily, whichever is less frequent.

Caution

Any unsafe condition disclosed by the inspection shall be corrected before operation of the jack is resumed. Repairs should be performed only by designated qualified personnel.

The following items shall be visually inspected

and the jack should be observed during operations for deficiencies which might appear between frequent inspection. Any deficiencies shall be carefully examined and determination made whether or not they constitute a hazard. If such a determination is made, the jack shall be removed from service.

- A. Check for cracked or broken cylinder body.
- B. Inspect for leaking hydraulic fluid.
- C. Check for scored or otherwise damaged cylinder plunger.
- D. Inspect for leaking, damaged or improperly assembled accessory equipment.
- E. Inspect for proper function of locking mechanism.

Note

A jack that has been idle for one year or more shall be inspected in accordance with Frequent Inspection.

4-4. Periodic Inspection

Visual inspection by designated qualified per-

sonnel, making record of apparent external conditions, provide the basis for a continuing evaluation.

- A. Normal service — one year
- B. Severe service — before each use

Perform inspection in the same manner as frequent inspections, except that records are kept. A dated inspection record shall be kept on a Periodic Inspections.

It is recommended that the Periodic Inspection be performed by an authorized service center or appropriate trained authorized individuals.

During Periodic Inspection if external appearance indicates possible internal difficulty, the ram shall be disassembled for cleaning and examined for internal wear or damage.

4-5. Load Test

Any altered or repaired jack shall be tested for its ability to sustain its rated load prior to regular use. The jack shall be operated to 100% of its capacity.

Table 4-1. Specifications

Model No.	5026
Capacity (tons)	50
Retracted Height - inches (mm)	26 (660)
Lift - inches (mm)	13 (330)
Extended Height - inches (mm)	39 (991)
Length - inches (mm)	25 (635)
Width - inches (mm)	26.8 (681)
Head Diameter - inches (mm)	3.75 (95)
Weight - lbs (kg)	400 (181)
Operating air - psi (bar)	90 (6.2)
Lift speed in/min (mm/min) No load/full load	19 (48)
Air consumption at full load cfm (L/min)	50 (1420)
Hydraulic Oil	
Less than 50° F (10° C)	ISO - 32 (150 SUS)
* Normal conditions	ISO - 48 (215 SUS)
Greater than 85° F (29° C)	ISO - 68 (315 SUS)
* Jack shipped with this type oil	
Reservior capacity - US Gallon (L)	2.5 (9.5)
Max. Tire Pressure - psi (bar)	35(2.4)

Section V

Preventative Maintenance

IMPORTANT:

Any repair or servicing which requires dismantling the jack should be performed in a dirt-free environment by a qualified technician.

Disconnect the jack from the air supply before performing maintenance or repair procedures.

5-1. Lubrication of the Air Driven Motor

An automatic air line oiler is recommended. Install the oiler in the air inlet line as close to the pumping unit as possible. Adjust the oiler to feed 1-3 drops of SAE #10 oil per minute (one drop for every 50-75 CFM of air) into the system.

5-2. Bleeding Air from the System

After use, air may accumulate in the hydraulic system if the reservoir level has been permitted to get too low. This air will cause the cylinder to respond in an unstable or slow manner. To remove this air:

1. Loosen plug on top of cylinder and start pump.
2. When oil replaces the air escaping (bleeding) from loosened plug in cylinder, stop pump and retighten the plug.

5-3. Draining and Flushing the Reservoir

The reservoir should be drained, flushed, and refilled with hydraulic oil approximately 300 hours after normal use. The following conditions would warrant more frequent changing of hydraulic oil:

- Very dusty environment and dust enters reservoir.
 - Hourly operations near 140° F - Evidence of oxidation and formation of gum, sludge, varnish.
 - Exposure to frequent extreme temperature change and high humidity resulting in excessive condensation in the reservoir while in storage.
1. Clean the pump exterior before the pump unit is removed from the reservoir.
 2. Remove the screws that hold the motor and pump assembly to the reservoir.

IMPORTANT

Do not damage the gasket or bump the filter or hydraulic pressure regulating valves when lifting the pump and motor off the reservoir.

3. After appropriately disposing of the used oil, clean the inside of the reservoir and fill with a suitable flushing oil. Rinse the filter clean.
4. Place the pump and motor assembly back onto

the reservoir and secure it with two machine screws assembled on opposite corners of the housing.

5. Connect a hose to the advance port of the valve and place the other end of the hose into the oil filler plug hole.
6. Run the pump on "advance" several minutes.
7. Remove the motor and pump assembly from the reservoir. Drain and clean the inside of the reservoir.
8. Fill the reservoir with Hydraulic oil. Place the pump and motor assembly (with gasket) back on the reservoir and tighten the screws securely and evenly.

5-4. Hydraulic fluid level

- Check the oil in the reservoir after each 10 hours of use.
- Proper oil level is within 1/2" of the filter plug when all cylinders are retracted.

5-5. Adding oil to the reservoir

- Use only hydraulic oil
 - ISO -32 (150 SUS @ less than 50° F)
 - ISO -48 (215 SUS @ Normal Conditions)
 - ISO -68 (315 SUS @ Greater than 85° F)
- Clean the entire area around the filler plug before removing the filler plug.
- Use a clean funnel with filter when adding oil.
- Cylinder(s) must be fully retracted and the power supply disconnected when adding oil to the reservoir.

5-6. Maintenance cleaning

- Keep the outer surface of the pump, all hose connections and any equipment hooked up to the pump as free of dirt and oil as possible.
- The breather hole in the filter plug must be kept clean and unobstructed at all times.
- All unused couplers are to be sealed with thread protectors.
- Change oil as recommended.

Section VI

Accessory Installation

6-1. Hydraulic Gauge

1. Remove the pipe plug from the gauge port.
2. Remove the four cap screws holding the valve to the pump plate and lift the valve off the pump plate.
3. Apply thread sealant or teflon tape to the threads of the gauge into the gauge port and tighten with a wrench.
4. Assemble the valve back onto the pump plate.

Do NOT kink the air lines.

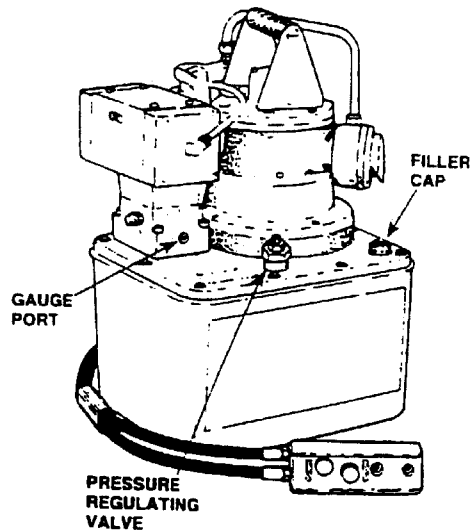

Figure 6-1. Hydraulic Gauge

Section VII

Troubleshooting Guide

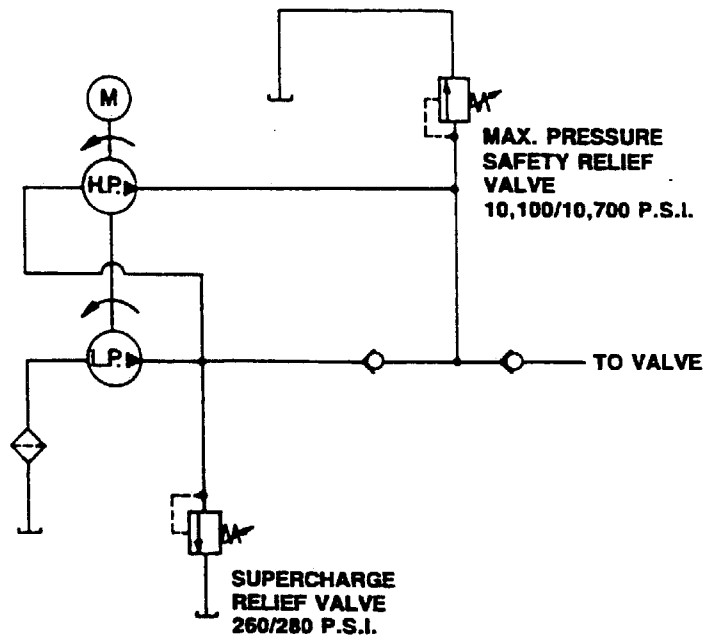

Figure 7-1. Hydraulic Schematic

! Warning

To prevent injuries, any repair work or troubleshooting must be done by qualified personnel familiar with this equipment.

Note:

- Use proper gauges and equipment when troubleshooting.
- Depending on the pump version, it is often best to check for leaks by using a hand pump and

applying pressure to the suspect area without the motor running. Watch for leaking oil and follow it back to its source.

- Plug the outlet ports of the pump when checking for leakage to determine if the leakage is in the pump or if it is in the cylinder.
- Refer to the Parts List and the hydraulic schematic when using this troubleshooting guide.

Problem

Pump is not delivering oil or delivers only enough oil to advance cylinder partially or erratically

Cause

1. Oil level too low
2. Air in system
3. Air leak in suction line.
4. Dirt in pump or filter plugged.
5. Oil is bypassing through the double-acting cylinder
6. Cold oil or oil is too heavy (Hydraulic oil is of a higher viscosity than necessary)
7. Relief valve or low pressure unloading valve out of adjustment.
8. Defective directional valve
9. Sheared drive shaft key(s)
10. Motor rotating in the wrong direction
11. Vacuum in reservoir
12. Low pressure pump worn

Solution

1. Fill reservoir to within $\frac{1}{2}$ " of filler plug with all cylinders retracted.
2. Bleed the system
3. Check and tighten the suction line.
4. Pump filter should be cleaned and if necessary, pump should be dismantled and all parts inspected and cleaned.
5. By removing the ram and capping the hoses, the cylinder pump and valve can be checked. Observe whether or not the pump will hold pressure.
6. Change to lighter oil.
7. Readjust as needed.
8. Inspect all parts carefully and replace if necessary.
9. Replace
10. Air line connected into wrong port
11. Check for plugged vent in filler plug.
12. Clean pump parts, replace worn gerotor set, repair or replace the pump housing.

Problem

Pump builds pressure but cannot maintain pressure.

Cause

1. Check to see if there are any external leaks. If no oil leakage is visible, the problem is internal. Remove jack cylinder from the system to insure that the leak is not in the cylinder.
2. To test for a leaking control valve, lift the pump from the reservoir but keep the filter in the oil. Remove the drain line to see if the oil is leaking from the valve. If the valve is not leaking, the internal check valve could be leaking. Refer to the "Note" concerning checking for oil leaks at the beginning of this troubleshooting guide.

Solution

1. Reseal leaking pipe fittings with pipe sealant.
2. Clean, reseal or replace control valve parts. If the internal check valve(s) are leaking, the pump must be dismantled and the seat areas repaired, poppets replaced, shear seals relapped, etc.

Problem

Pump will not build full pressure

Cause

1. Faulty pressure gauge.
2. Check for external leakage
3. Check the external pressure regulator. Check filter, the relief valve setting.
4. Look for internal leakage in jack cylinder.
5. Check for leaks in the flow control valve.
6. Inspect the pump for internal leakage. Check high pressure pump inlet or outlet ball checks.
7. Sheared Key(s)
8. Inadequate air pressure

Solution

1. Calibrate gauge
2. Seal any faulty pipe fitting with pipe sealant
3. Lift the pump from the reservoir but keep the pump immersed in oil. Note the pressure reading when the relief valve begins to open up. If functioning normally, it should start to leak off at relief valve pressure.
4. Remove the cylinders from the pump. If the pump builds full pressure, the cylinder is defective.
5. Clean and reseal or replace parts.
6. Same procedure as above but look for leaks around the entire inner mechanism. If there are no visible leaks the high pressure pump may be leaking. Remove all parts. Check the valve head assembly body for any damage to the seat area. Clean and reseal if necessary. Inspect for damage and replace parts if necessary, then reassemble.
7. Replace
8. Increase air pressure.

Problem

Jack cylinder will not retract

Cause

1. Defective valve
2. Inadequate air pressure
3. Locking Shoes Engaged
4. Load Lowering Valve toally closed.

Solution

1. Check valve operation and inspect parts. Replace if necessary.
2. Increase air pressure
3. Raise cylinder approximately 1/4" or until locking shoe piston heads are flush with their holders.
4. Open Load Lowering Valve.

Problem

Pump delivers excess oil pressure

Cause

1. Check pressure gauge
2. Relief valve not properly set

Solution

1. Calibrate gauge
2. Reseat the relief valve

Section VIII
Parts Drawings and Lists

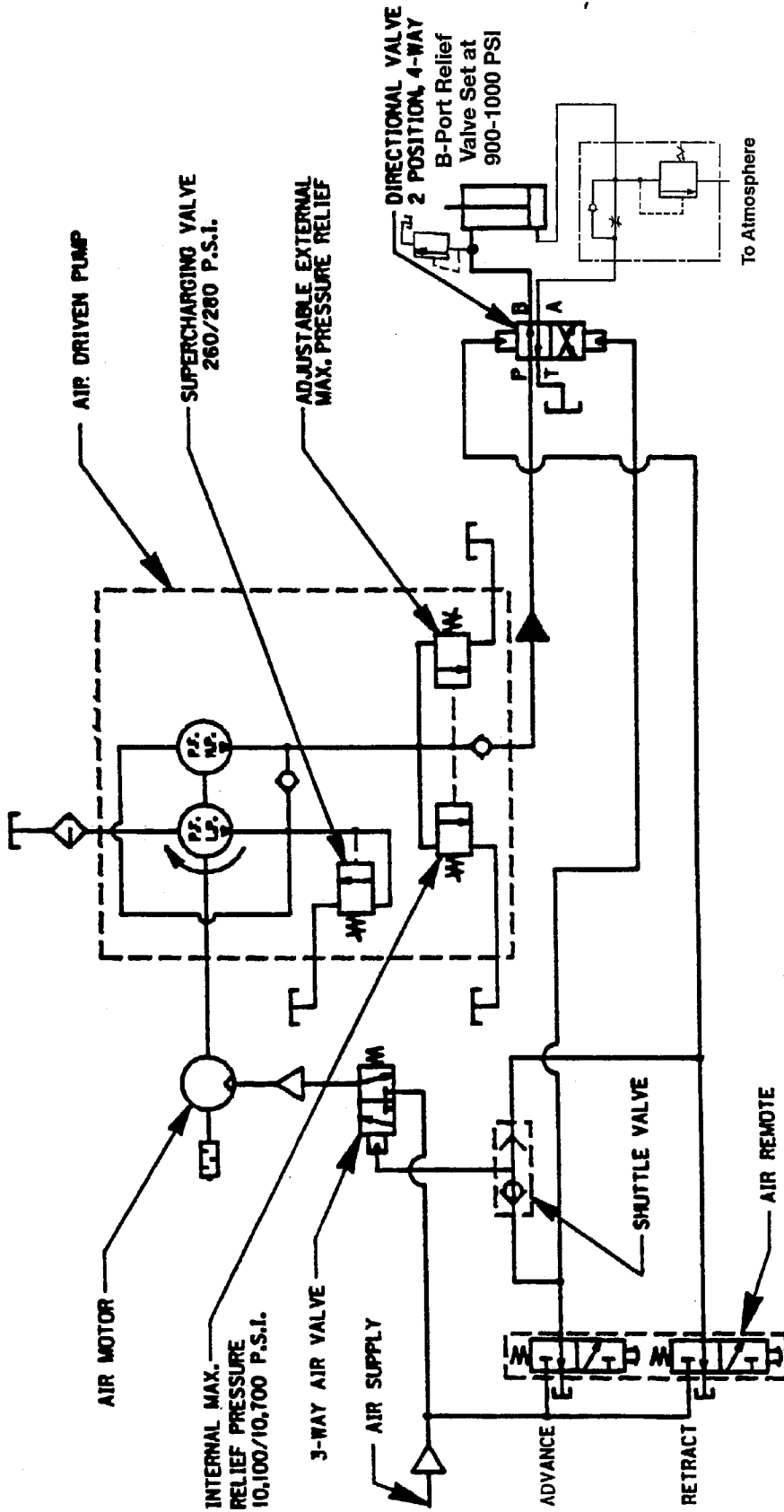
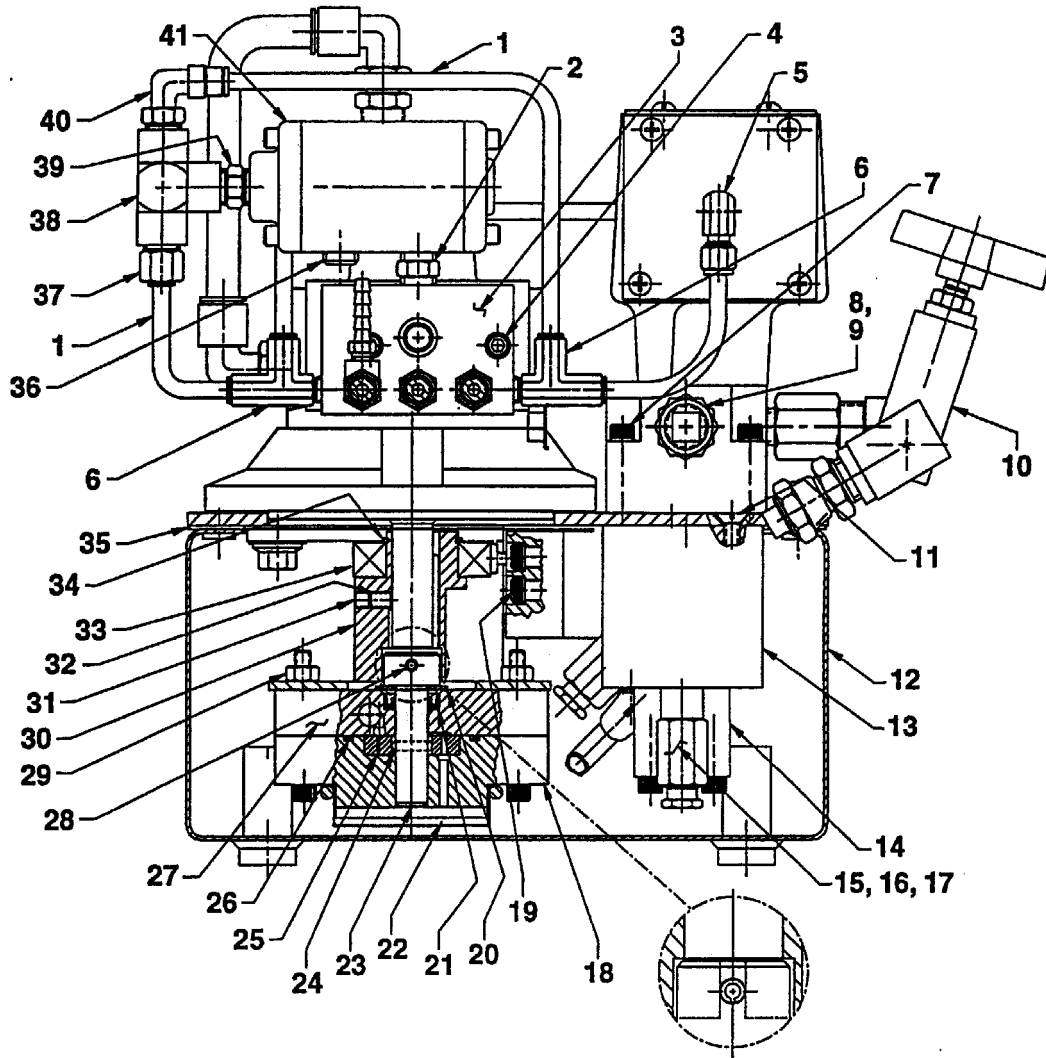

Figure 8-1. Hydraulic Schematic for Pump B-J50-50

Figure 8.2 General Pump Assembly - Side View



Ref. No.	Description	Part Qty	Part No.
1	Tubing, Polyethylene	2.42'	15883
2	Fitting, Straight (3/8 NPTF)	1	10673
3	Manifold	1	351443
4	Screw, Soc Hd (1/4-20 x 1-1/2)	2	10022
5	Fitting, Elbow 90° (1/8 NPTF)	1	250463
6	Fitting, Tee (1/4 NPTF)	2	214342
7	Screw, Soc Hd (1/4-20 x 1-3/4)	4	10854
8	Fitting, Plug (3/8 NPT)	2	13273
9	Fitting, Straight (1/4 NPTF)	1	10616
10	Valve, Manual	1	46647
11	Screw, Flat Hd (1/4-20 x 3/4)	2	11529
12	Reservoir	1	65984GY8
13	Body, Check	1	64612
14	Block, Retaining	1	350930
15	Tube, Suction	1	202781
16	Fitting, Straight (1/8 NPTF)	1	18841
17	Valve, Relief (1000 PSI)	1	21278-10
18	Housing, Gerotor Lower	1	64580
19	Screw, Soc Hd (1/4-20 x 1-1/2; Supplied with valve; Torque to 180/200 in. lbs.)	4	10022
20	Washer, Brass (1.13 x .51)	1	12595
21	Seal, Oil (.88 x .50 Nitrile)	1	304830

Ref. No.	Description	Part Qty	Part No.
22	Support, Filter	1	21846
23	Shaft, Gerotor	1	350940
24	Pin, Gerotor Drive	1	209794
25	Set, Gerotor	1	304826
26	O-ring (2.12 x 1.93 Nitrile)	1	10922
27	Housing, Upper Gerotor	1	64623
28	Pin, Roll (.19 x 1.50)	1	12298
29	Nut, Hex (1/4-20)	2	10199
30	Eccentric	1	420840
31	Screw, Hex Set (1/4-20 x 3/8 Lg; Torque to 60/80 in. lbs.)	1	10519
32	Screw, Hex Set (1/4-20 x 1/4 Lg; Torque to 60/80 in. lbs.)	1	10136
33	Bearing, Ball	1	209805
34	Ring, Retaining Ext. (1.18 x .052)	1	209798
35	Gasket, Reservoir	1	420931
36	Fitting, Plug (3/8 NPTF)	1	10909
37	Fitting, Straight (1/4 NPT)	1	251054
38	Fitting, Tee (1/4 NPTF)	1	252998
39	Fitting, Straight (1/4 NPTF)	1	12328
40	Fitting, Elbow 90° (1/4 NPTF)	1	15457
41	Valve, Air Operated 3 Way	1	350345

Figure 8-2. Parts List for General Pump Assembly - Side View

Figure 8-3. General Pump Assembly - Top View

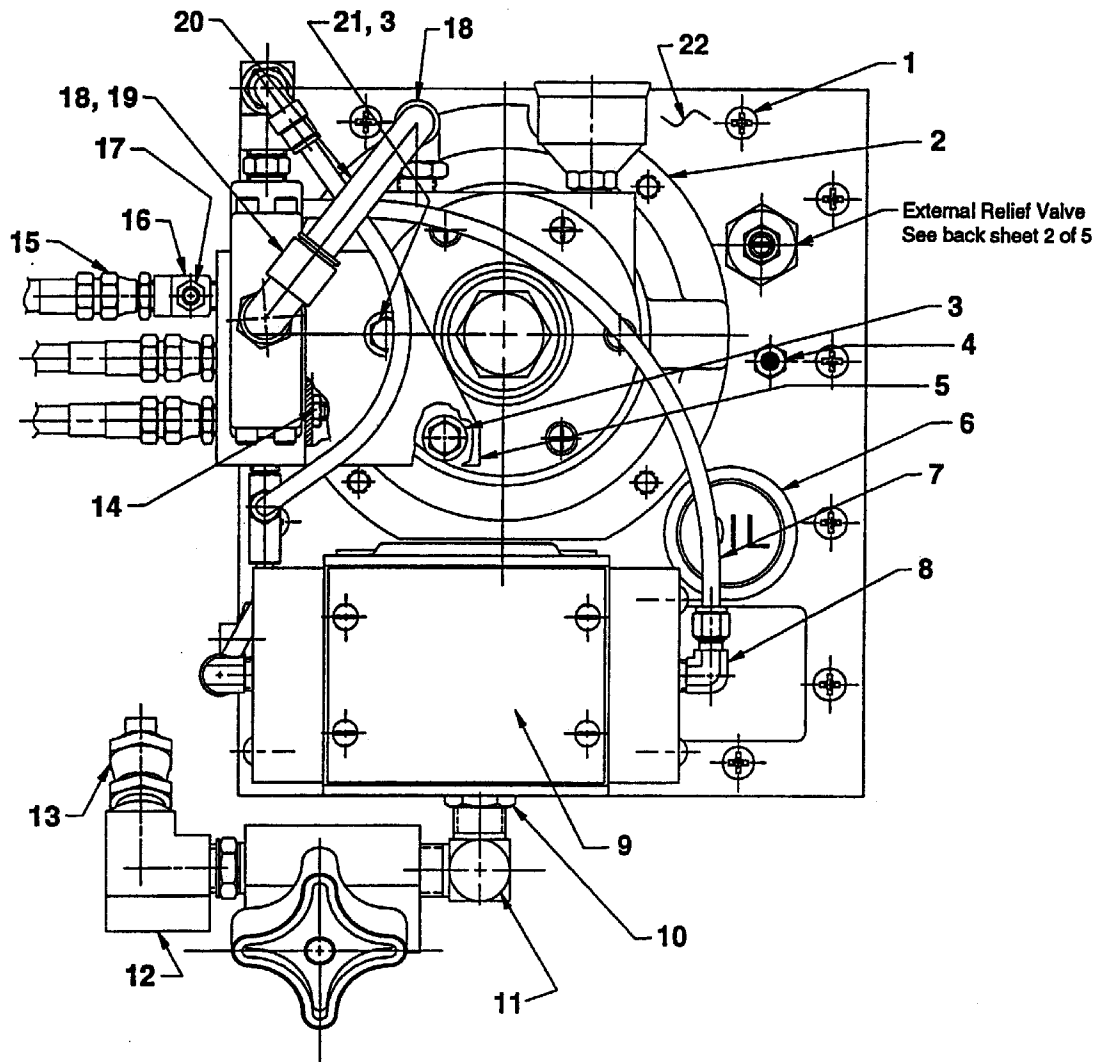

Ref. No.	Description	Part Qty	Part No.
1	Screw, Rd Hd (1/4-20 x 3/4; Torque to 60/80 in. lbs.)	14	10177
2	Motor, Air	1	421808WH2
3	Washer, Plain (.63 x .29)	12	12719
4	Vent, Breather Filter	1	251599
5	Bracket, Mounting	1	351864
6	Cap, Filter	1	350925
7	Tubing, Polyethylene	2.42'	15883
8	Fitting, Elbow 90° (1/8 NPTF)	1	250463
9	Valve, Air 4 Way Pump Mount	1	9594
10	Fitting, Straight (Supplied with valve)	1	9689
11	Fitting, Elbow 90° (3/8 NPTF)	1	16254

Ref. No.	Description	Part Qty	Part No.
12	Fitting, Elbow 90° (3/8)	1	9686
13	Fitting, Straight (3/8 NPTF)	1	10469
14	Nut, Hex (1/4-20)	2	10199
15	Fitting, Straight (1/8 NPTF)	3	208218
16	Fitting, Tee	1	19463
17	Fitting, Hose (1/8 NPTF)	1	15913
18	Fitting, Elbow 90°	2	252297
19	Fitting, Straight (3/8 NPTF)	1	10676
20	Tubing, Nylon	.75'	252296
21	Screw Hex Hd Cap (1/4-28 x 1)	2	10014
22	Plate, Cover	1	65983BK2

8-3 Parts List for General Pump Assembly - Top View

Figure 8-4. General Pump Assembly - Bottom View

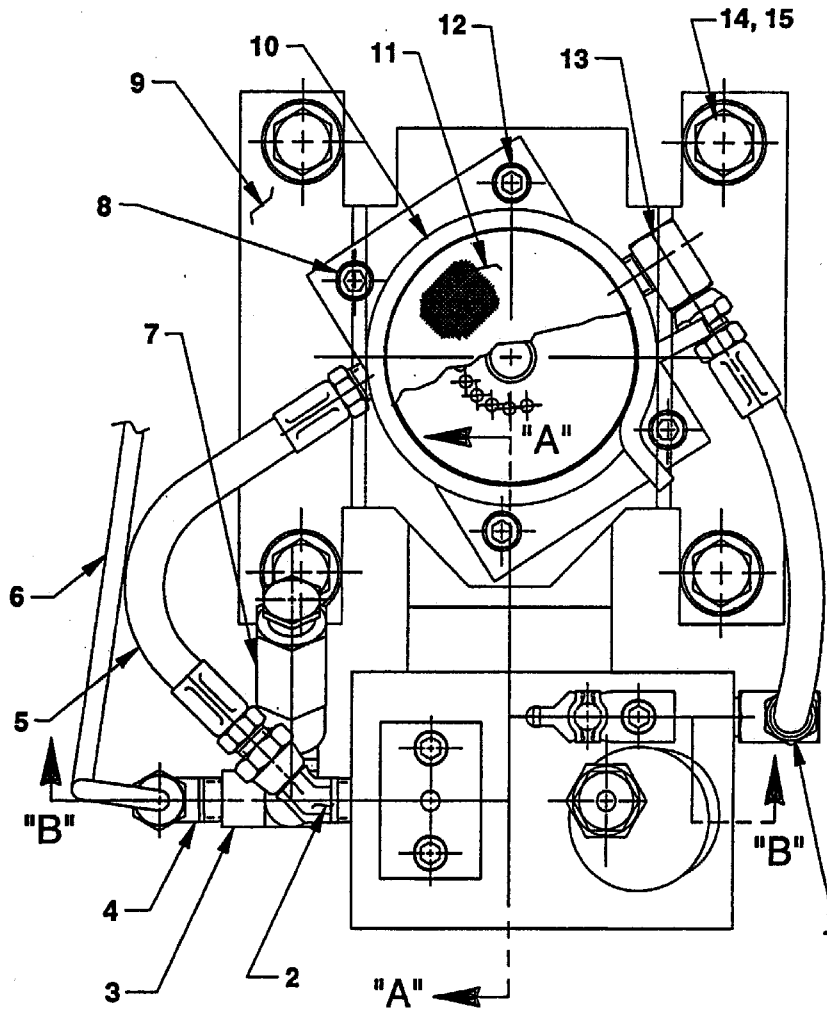

Ref. No.	Description	Part Qty	Part No.
1	Fitting, Elbow 90° (1/8 NPTF)	1	13229
2	Fitting, Elbow 45° (1/8 NPTF)	1	251800
3	Fitting, Tee (1/8 NPTF)	1	18969
4	Fitting, Elbow 90° (1/8 NPTF)	1	16177
5	Hose, 1/2' Polyurethane	2	304819
6	Tube, Oil Line	1	253396
7	Valve, Relief (10,000 PSI)	1	21278
8	Screw, Soc Hd (1/4-20 x 1-1/2; Torque to 60/80 in. lbs)	2	10022
9	Bracket, Gerotor Housing	1	58481
10	Clamp, Hose	1	11461
11	Filter	1	21608
12	Screw, Soc Hd (1/4-20 x 2; Torque to 60/80 in. lbs.)	2	10890
13	Fitting, Elbow 90° (1/8 NPTF)	1	14440
14	Screw, Fig Hex Hd (3/8-16 x 1; Torque to 230/250 in. lbs.)	4	213663
15	Washer, Plain (.82 x .41)	4	10258

8-4. Parts List for General Pump Assembly - Bottom View

Figure 8-5. External Relief Valve

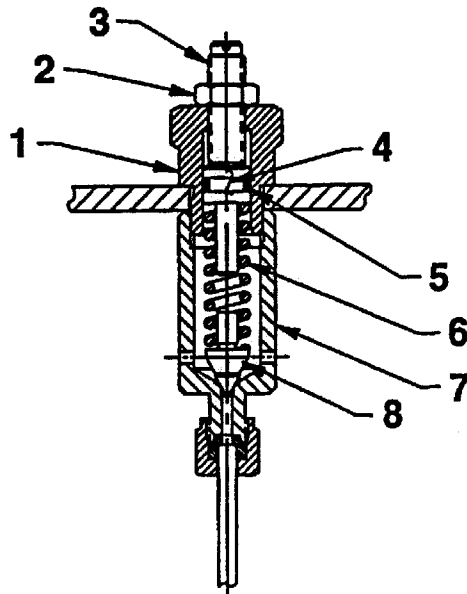

Ref. No.	Description	Part Qty	Part No.
1	Cap, Valve	1	21305
2	Nut, Hex Jam (3/8-24)	1	10386
3	Screw, Adjust (3/8-24 x 1-1/4)	1	22362
4	Guide, Spring	1	21306
5	O-ring (.50 x .37 Nitrile)	1	10268
6	Spring (.46 OD x 1.67 x .11WS)	1	10495
7	Body, Valve	1	22361
8	Stem, Valve	1	21046

8-5. Parts List for External Relief Valve

Figure 8-6. General Pump Assembly - Section A-A

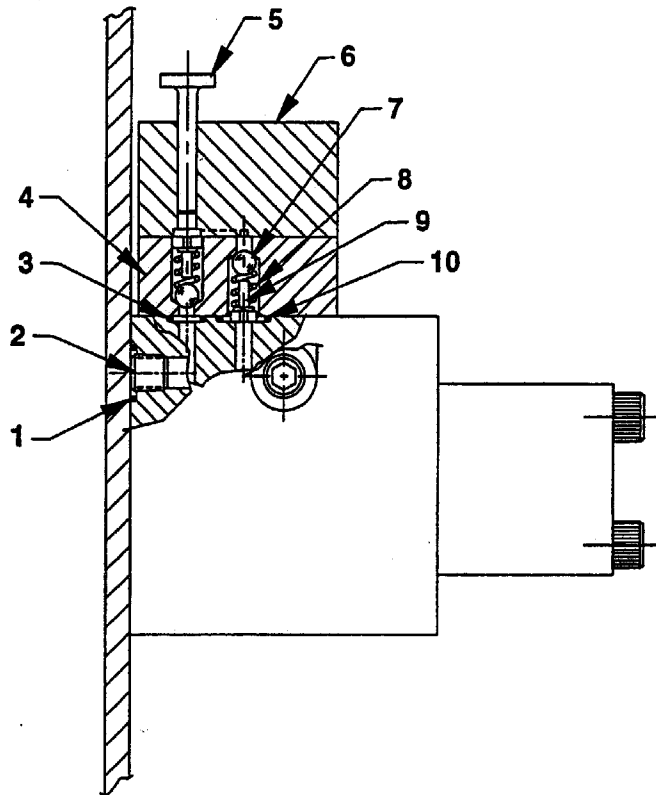

Ref. No.	Description	Part Qty	Part No.
1	O-ring (.50 x .37 Nitrile)	1	15279
2	Fitting, Plug (1/16 PTF)	1	15130
3	O-ring (.31 x .18 Nitrile)	1	10265
4	Block	1	45559
5	Piston, High Pressure	1	305526
6	Block	1	45866
7	Ball (3/16 dia. Steel)	2	12223
8	Spring (.16 OD x .72 x .01 WS)	2	10445
9	Guide, Ball	2	24549
10	O-ring (.43 x .31 Urethane)	1	14763

8-6. Parts List for General Pump Assembly - Section A-A

Figure 8-7. General Pump Assembly - Section B-B

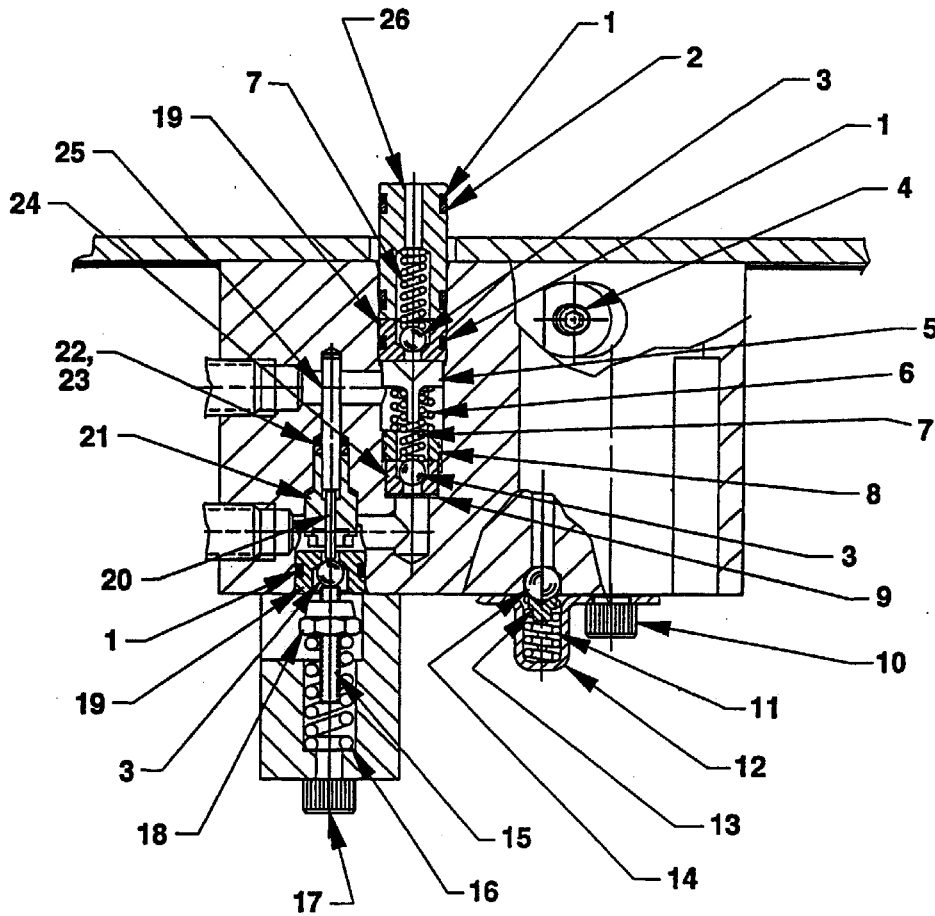

Ref. No.	Description	Part Qty	Part No.
1	O-ring (.50 x .37 Nitrile)	4	10268
2	Washer, Backup (.50 x .38)	2	11863
3	Ball (3/16 dia. Steel)	3	12223
4	Fitting, Plug (1/16 PTF)	1	15130
5	Stop, Outlet Ball	1	251601
6	Spring (.25 OD x .41 x .02 WS)	1	10444
7	Spring (.16 OD x .72 x .01 WS)	2	10445
8	Screw, Hol Lock (7/16-20 x 1/4)	1	209797
9	Washer, Copper (.37 x .25)	1	10442
10	Screw, Soc Hd (1/4-20 x 3/8)	1	10002
11	Spring (.24 OD x .63 x .04 WS)	1	15691
12	Retainer, Spring	1	350577
13	Adapter, Ball & Spring	1	200796
14	Ball (7/32 dia. Steel)	1	10374

Ref. No.	Description	Part Qty	Part No.
15	Screw, Hex Set (10-24 x 1 Lg.)	1	251067
16	Spring (.36 OD x 1.00 x .05 WS)	1	14484
17	Screw, Soc Hd (1/4-20 x 1-3/4; Torque to 60/80 in. lbs.)	2	10854
18	Nut, Hex Lock (10-24)	1	207405
19	Seat, Replaceable	2	251065
20	Pin, Dowel (.06 x .50)	1	251611
21	Guide	1	251068
22	O-ring (.25 x .12 Urethane)	1	17797
23	Washer, Backup (.24 x .13)	1	214992
24	Seat, Replaceable	1	209787
25	Pin, Dowel (.13 x 1.00)	1	16471
26	Bushing	1	251581

8-7. Parts List for General Pump Assembly - Section B-B

Figure 8-8. Air Motor for Pump

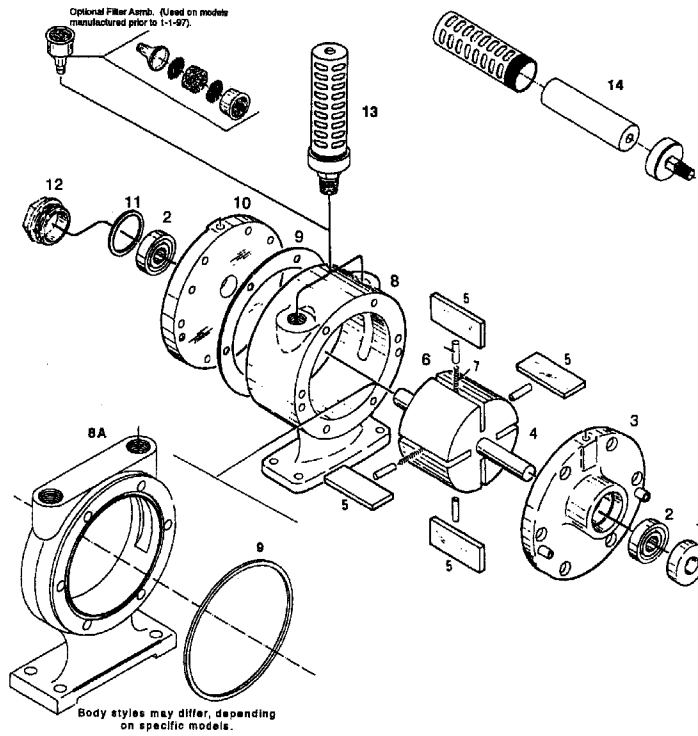

Ref. No.	Description	Part Qty	421808WH2
1*	Shaft Seal	1	B2328
2*	Bearing, Dead	1	AA299-J
2*	Bearing, Drive	1	AB519
3	End Plate, Drive	1	AG707
4	Rotor Assembly	1	AM455A
5*	Vane	4	AB876
6*	Push Pin	4	AM467
7*	Vane Spring	2	AM466
8	Body	1	AM410
9*	Shims	2	B330
10	End Plate, Dead	1	AC728
11*	End Cap, Gasket	1	AA46
12	End Cap, Dead	1	AM307D
13	Muffler Assembly	1	AL445
14*	Muffler Cartridge		AL458
*	Muffler Felt (for use with AC 980 Muffler Assembly)	1	AC983
	Service Kit	1	K206A

8-8. Parts List for Air Motor for Pump

Figure 8-9. Hand Switch Assembly

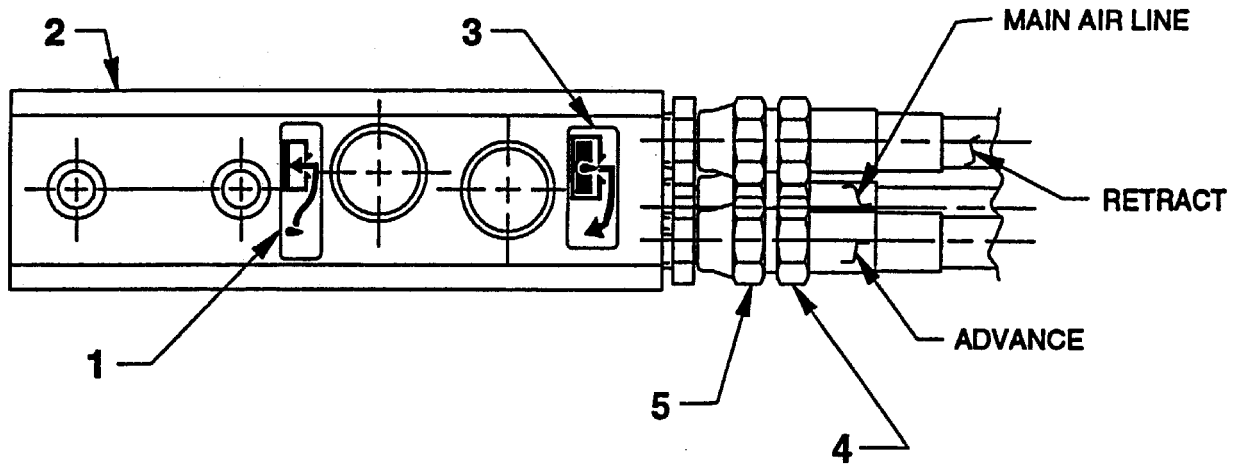

Item No.	Part No.	No. Req'd.	Description
1	421265	1	Air Operated Hand Control
2	251759	1	Instruction Decal (Pump)
3	45052	1	Three Strand Hose (12 ft. without spring guards; Note: Connect hose assembly to remote control and pump as shown. Color coded or numbered ends must correspond to numbers on the remote control and pump unit.)
4	208218	3	Straight Fitting (1/8 NPTF)
5	251760	1	Instruction Decal (Release)

8-9. Parts List For Hand Switch Assembly

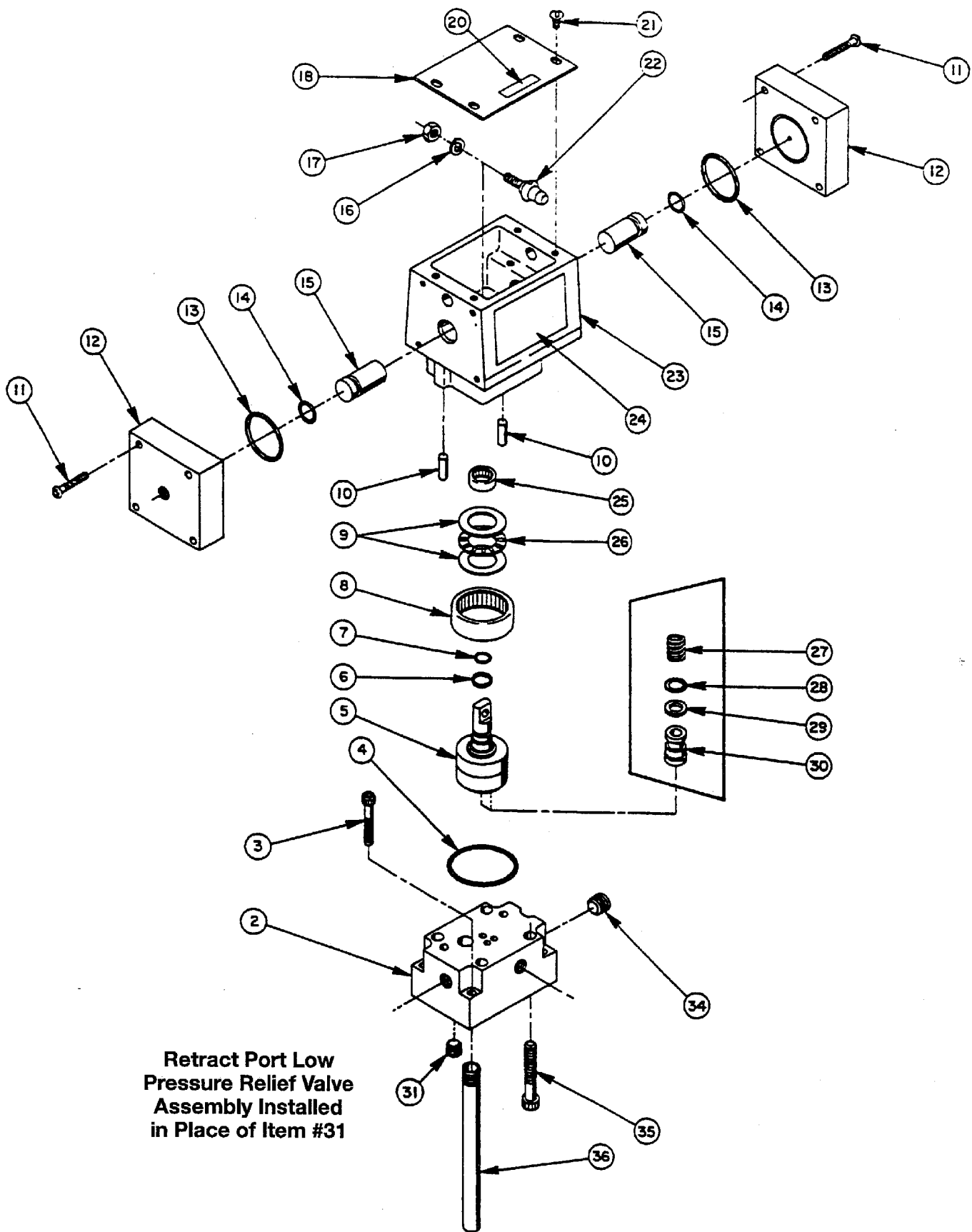

Figure 8-10. Valve Assembly

8-10. Parts List Valve Assembly

Item No.	Part No.	No. Req'd.	Description
2	61078	4	Subplate
3	10222	4	Soc Hd Mach Screw (1/4-20 UNC x 1 1/2 lg)
4	*214699	1	O-ring (2-3/16 x 2" x 3/32)
5	52064	1	Rotor
6	*208672 *10268	1 1	Glyd Ring O-ring (1/2 x 3/8 x 1/16, -012)
8	17505	1	Needle Roller Bearing
9	15935	2	Thrust Washer
10	17567	2	Spring Pin
11	13025	8	Mach Screw (#8-32 UNC x 1 1/4 lg Torque to 10/15 in. lbs.
12	45209	2	Air Cap
13	*14852	2	O-Ring (1 9/16 x 1 3/8 x 3/32, -126)
14	*210230	2	O-Ring (11/16 x 1/2 x 3/32, -112)
15	208673	2	Cam Plunger
16	10245	1	Lockwasher
17	15504	1	Locknut
18	303976	1	Cover
20	209383	1	Patent Decal
21	10164	4	Machine Screw (#10-24 UNC x 3/8 Lg.)
22	304030	1	Lever
23	61077	1	Valve Body
24	208715	1	Part No. Decal
25	208671	1	Needle Roller Bearing
26	12188	1	Roller Bearing
27	15095	2	Compression Spring
28	*10265	2	O-ring (5/16 x 3/16 x 1/16, -008)
29	*15174	2	Backup Washer (5/16 x 3/16 x 3/64, -008)
30	303935	2	Shear Seal
31	15499	1	Pipe Plug (1/8 NPTF)
34	10479	1	Pipe Plug (1/4 NPFT)
35	18328	4	Soc. Hd. Cap Screw (5/16-18 x 2" Lg.)
36	200609	1	Drain Tube

Parts Included But Not Shown

13999	1	Straight Fitting
16797	1	90° Elbow Fitting

Part numbers marked with an (*) asterisk are contained in Repair Kit No. 300332.

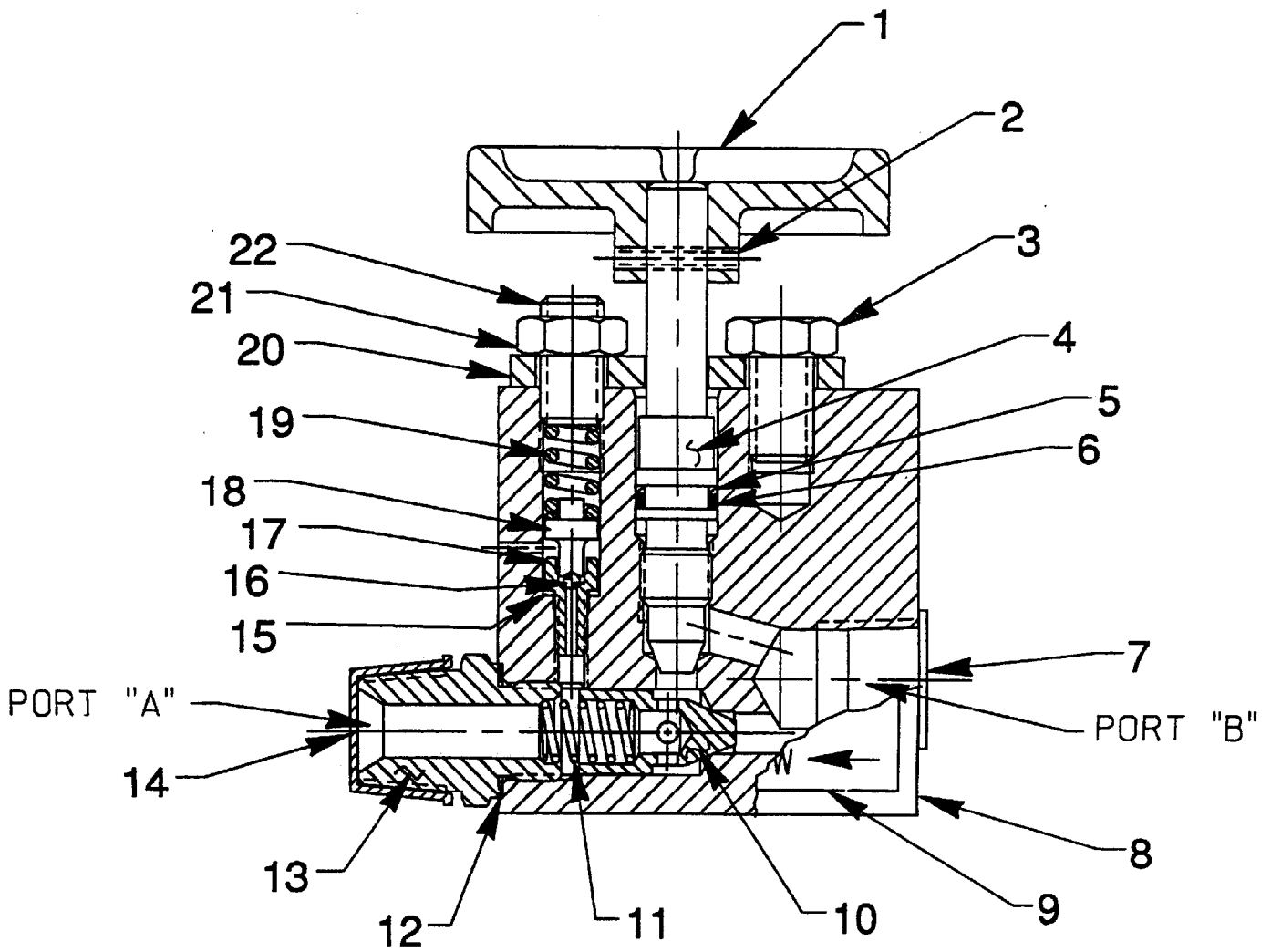

Figure 8-11. Load Lowering Valve

8-11. Parts List For Load Lowering Valve

Item No.	Part No.	No. Req'd.	Description
1	23272	1	Knob
2	10895	1	Roll Pin
3	250951	1	Hex Hd. Cap Screw
4	307022	1	Control Valve Stem
5	118633	1	Backup Washer (1/2 x 3/8 x 1/16, -0112)
6	10268	1	O-Ring (1/2 x 3/8 x 1/16, -012)
7	12545	1	Plug
8	52861	1	Valve body
9	212983	1	Trade name Decal
10	20771	1	Poppet
11	10425	1	Compression Spring (3/8 OD x 3/4" lg.)
12	10261	1	Copper Washer (3/4 x 19/32 x 1/32
13	20879	1	Connector (Torque to 40/45 ft. lbs.)
14	12546	1	Cap
15	14319	1	Copper Washer (5/16 x 3/16 x 1/32
16	17238	1	Ball (3/32 dia.)
17	203364	1	Replaceable Seat (Torque to 40/50 in. lbs.)
18	29785	1	Ball Retainer
19	14475	1	Compression Spring (5/16 OD x 5/8" lg.)
20	202653	1	Stop Plate
21	10386	1	Jam Nut (3/8-24 UNF)
22	16732	1	Set Screw

8-13. Specifications

This is a valve that features precision metering for controlled cylinder return and built in pressure relief. The valve permits freeflow as the ram is extended. The built in check feature automatically locks and holds the load in the raised position until the operator opens the valve. The unit may be preset to provide consistent metered return of the load or the operator may select the rate of return with each actuation.

8-14. Operation

The direction of free flow is marked on one side of the valve body; note before installing valve. Connect port "A" to the extend side of the cylinder and port "B" to the control valve. On double acting cylinders the load lowering valve should not be completely closed when pressurizing the opposite port.

Note: This valve has a built in safety device that will vent system pressure to the atmosphere if accidentally pressurized beyond 12,500 PSI/ 875 Bar.

Pressure Relief Setting 12,500 PSI/ 875 Bar	Max. Flow Rate 5 Gal/Min	Max. Operating Pressure 10,000 PSI/700 Bar
---	------------------------------------	--

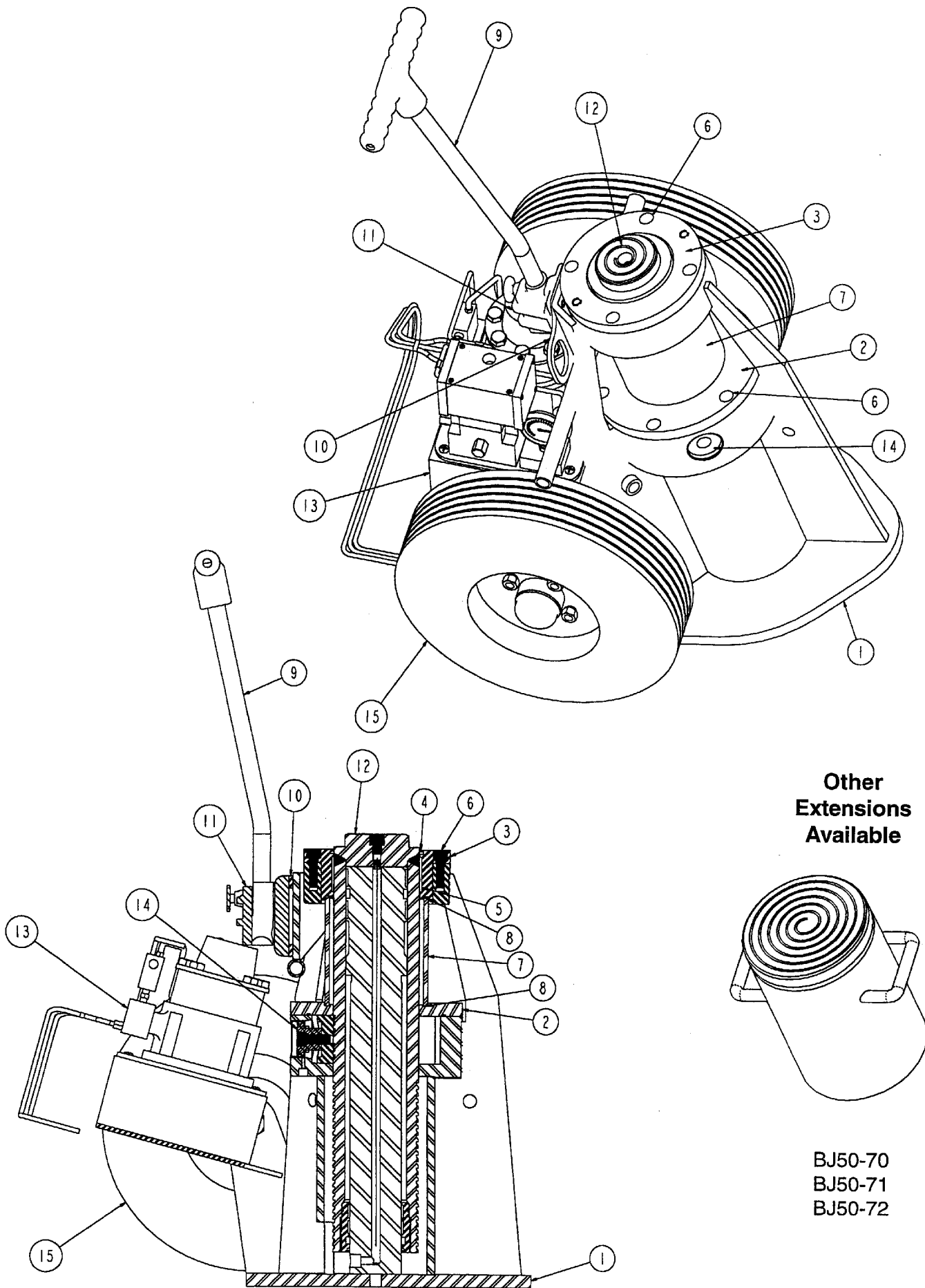

Figure 8-12. 5026 BOSSMAN Jack Assembly

8-12. Parts List 5026 BOSSMAN Jack

INDEX NO.	Description	PART NO.	PART NO.	QTY REQ'D
	Main Base Parts			
1	Main Base Weldment	BJ50-34		1
2	Key Retainer Plate	BJ5770		1
3	Top Cap	BJ5301		1
4	Wiper (Top Cap)	BJ50-7		1
5	Wear Guide (Top Cap)	BJ50-8		2
6	Cap Screw - 1/2"-20 x 1 1/4" Lg	S49-140C		12
7	Safety Sleeve	BJ5021		1
8	Seal (Safety Sleeve)	BJ3005		2
	Capacity Label	BJ5003		1
	Warning Label	BJ3002		1
	Duff-Norton Nameplate	BJ3001		1
	Bossmen Nameplate	BJ3000		1
	Handle Parts			
9	Handle Weldment	P587-2		1
10	Lifting Eye	X4856		1
	Handle Pin	X4229		1
	Hex Bolt - 3/8"-16 x 1 1/4" Lg	S44-35C		4
	Lock Washer - 3/8"	H4085PC		4
11	Handle Bracket Assembly	P584		1
	Bracket		X3505	1
	Latch Plunger		X4141	1
	Latch Sleeve		X2854	1
	Knob		X2853	1
	Spring		S37-26C	1
	Hydraulic Cylinder Parts			
12	Cylinder Assembly	BJ50-06A		1
	Outer Tube Weldment		BJ50-08A	1
	Inner Rod		BJ50-09A	1
	Cylinder Head		BJ5170A	1
	Cylinder Seal Kit		BJ50S	1
	Cylinder Seal Kit	BJ50S		1
	Wiper		BJ50-1	1
	Gland Wear Guide		BJ50-2	2
	Rod Seal		BJ50-3	1
	Inner Rod Wear Guide		BJ50-4	2
	Piston Seal		BJ50-5	1
	O-Ring With Backup		BJ50-6	1
	Cylinder Bleed Plug	H5267C		1
	Cap Screw - (Cylinder Cap) 1/2"-20 x 1/2" Lg	S49-147C		1
	Cap Screw (Cylinder Mounting) - 1/2"-20x1 1/2 Lg	S49-143C		3
	Power Unit Parts			
13	Power Unit	BJ50-50		1
	Lowering Valve (Included in Index No. 3)	BJ2050	BJ2050	1
	Air Control & Hose Assembly (Included in Index No. 3)	BJ150-20		1
	Air Hose Protective Cover	BJ2400		1
	Hydraulic Pressure Gauge	BJ50-17		1
	Pipe Nipple (Gauge)	BJ1801		1
	90 Deg Swivel Fitting (Gauge)	BJ1803		1
	Hex Bolt (Pump Mounting) - 1/2"-20 x 3/4" Lg	S44-194C		4
	Flat Washer (Pump Mounting) - 1/2"	S3-28C		4
	Hydraulic Plumbing Parts			
	Hydraulic Hose Assembly	BJ150-15		1
	Pipe Nipple (Extend Port) - 3/8" x 6" Lg		BJ1700	1
	Swivel Fitting - 3/8" FP x 3/8" Swivel Nut x 90 Deg		BJ1701	2
	Retract Hose - 3/8" x 12" Lg		BJ1702	1
	Extend Hose - 3/8" x 15" Lg		BJ1703	1
	Pipe Nipple (Retract Port) - 3/8" x 4" Lg		BJ1704	1
	Air Plumbing Parts			
	Air Hose & Fitting Kit	BJ50-14		1
	Elbow Fitting - 1/8" MP x 1/8" FP x 90 Deg		BJ1650	1
	Tee Fitting - 1/8" MP x 1/8" FP x 1/8" FP		BJ1651	2
	Barb Fitting - 1/8" MP x 1/4" Hose		BJ1652	5
	Hose - 1/4" x 12" Lg		BJ1655-12	2
	Hose - 1/4" x 24" Lg		BJ1655-24	1
	Hose Clamp - 1/4" Hose		BJ1654	6
	Barb Fitting - 1/2" MP x 1/2" Hose		BJ1658	2
	Hose - 1/2" x 24" Lg		BJ1657-24	1
	Hose Clamp - 1/2" Hose		BJ1659	2
	Street Elbow - 3/8" MP x 1/2" FP		BJ1212	1
	Street Elbow - 1/2" MP x 1/2" FP		BJ1213	1
	Locking Mechanism Parts			
14	Lock Shoe	BJ5501		1
	Air Piston Kit	BJ50-12		3
	Piston		BJ5550	1
	O-Ring		BJ1551	1
	Bronze Liner		BJ1600	3
	O-Ring		BJ1601	3
	Wave Compression Spring	BJ5551		3
	Cap Screw - 1/2"-20 x 1 1/4" Lg	S49-140C		3
	Wheel Assembly Parts			
15	Wheel Assembly	BJ150-27		2
	Tire & Rim		BJ2300	1
	Idler Hub		BJ2301	1
	Dust Cap		BJ2305	1
	Tapered Roller Bearing		SK2658-5	2
	Castle Nut - 1"-14		S56-33C	1
	Cotter Pin		S2-24C	1
	Seal		BJ1004	2
	Lug Nut		S56-39C	4
	Axle	BJ2251		2
	Hex Nut (Axle) - 1"-14	S12-80C		2
	Flat Washer (Lowering Valve Side) - 1"	S3-68C		2
	Optional Extension Sets			
	Extension Set (6", 9" & 12")	BJ50-6912		1
	6" Extension	BJ50-70		1
	9" Extension	BJ50-71		1
	12" Extension	BJ50-72		1



Duff Norton Air Motor Jack Company

2111 4th Ave. N.

Billings, MT 59101

Phone: (406) 252-4294

Fax: (406) 252-4812